

# SPECIFICATIONS



**8HBC30.40**

**CENTER-CONTROL RIDER**

**ELECTRIC**

# 6,000 – 8,000 lbs • Standard Features

## PERFORMANCE

---

- 6,000 & 8,000 lb capacity
- 24-Volt electrical system
- 6" lift
- AC Drive System with thermal protection and current limiting
- Fault code memory with hour meter reading
- Regenerative braking
- Programmable performance parameters
- Multiple hour meter indicator
- Battery discharge indicator with lift interrupt
- Fused control and power circuits
- On/off key switch
- Lift limit switch
- Hydraulic overload protection valve
- Dual lift cylinder design

## DURABILITY

---

- Controller Area Network (CAN-bus) communications
- Welded construction with reinforced heavy-duty bumper
- Powder-coat paint finish
- Box rail fork construction
- Steel bulkhead wrappers
- Forged rectangular steel tension rods
- Heavy-duty bushings and pins
- Solid trail fork castings
- Tapered fork tips with pallet entry slides
- Four-point lift linkage
- High-strength polymer service cover
- Fiberglass reinforced rubber drive tire
- Polyurethane load wheels with steel hubs
- Hall-effect switches
- 48" load backrest extension

## ERGONOMICS

---

- Multifunction control handle with ergonomically angled hand grips
- Dual thumb wheels with twist grips for directional control and travel speed
- Fingertip control of lift, lower and horn functions
- High-speed interlock
- Dual hand brake levers
- Adjustable height control handle (3-Positions)
- Low-effort control handle
- Bubble-cushioned operator floor mat, padded backrest and knee pad
- Walk-through operator compartment
- Low platform step height

## SERVICEABILITY

---

- AC drive motor (no brushes or commutator)
- Self-adjusting electric disc brake
- One-piece, lightweight service access cover
- Teflon® coated Polyube™ lift linkage bushings (maintenance free)
- Error indicator with self-diagnostics

## SAFETY

---

- Wrap-around hand guard
- Polyurethane torsion block stabilizing casters
- Electronic horn

## OPTIONAL EQUIPMENT

- Battery compartment rollers with dual side gates
- Battery side gates interlock switches
- Jog buttons with turtle speed
- Turtle speed (3-position key switch)
- Various drive tires and load wheels
- Steel front bumper skirt
- Pallet entry/exit rollers
- Spring-loaded stabilizing casters
- Cold storage conditioning
- 60" load backrest extension
- 32" battery retaining wall
- Various fork lengths
- Various overall fork widths
- Amenities tray
- Power hook-up for on-board terminal
- Keyless on/off switch
- Controller splash guard
- Load wheel debris diversion device
- UL -approved model type E or EE

# 8HBC30 Specifications

## EXTERIOR DIMENSIONS (inches)

A	Fork Length	36	42	48	60	84 <sup>(1)</sup>	93 <sup>(1)</sup>	96 <sup>(1)</sup>	103 <sup>(1)(2)</sup>
B	Overall Length	90.3	96.3	102.3	114.3	138.7	146.5	148.7	155.7
C	Wheelbase – Lowered	72.8	78.8	84.8	96.8	105.2	105.2	105.2	112.2
D	Wheelbase – Raised	68.1	74.1	80.1	92.1	100.5	100.5	100.5	107.5
E	Turning Radius	74.7	80.6	86.5	98.3	106.6	106.6	106.6	113.5
F	Overall Fork Width	22 or 24 or 27			22.625 or 24.5 or 27.5				
G	Fork Width	9			10				

Gross Weight Without Batteries (lbs)	1280	1300	1320	1370	1730	1770	1780	1805
--------------------------------------	------	------	------	------	------	------	------	------

Units: inches

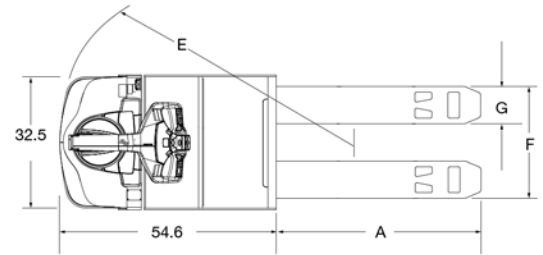

## BATTERY – 24 VOLT

Amps Max. (Ah)	750
Battery Connector/Color	SB-175/Gray
Battery Connector Cable Location	B
Battery Connector Cable Length (inches)	18
Dimensions of Battery Compartment LxW (inches)	31.5 x 13.44 <sup>(3)</sup>
Battery Weight Max. (lbs)	1500
Battery Weight Min. (lbs)	490

## PERFORMANCE

Travel Speed (mph)	Full Load/No Load	6.2/8.8
Gradeability %	Full Load/No Load	10/10

## TIRES

Type	Drive	Standard	Rubber
		Optional	Polyurethane
	Load	Polyurethane	
	Casters	Polyurethane	
Size	Drive – Dia. x Width (inches)	12 x 4.75	
	Load – Dia. x Width (inches)	3.25 x 5.91	
	Casters – Dia. x Width (inches)	4 x 2.5	

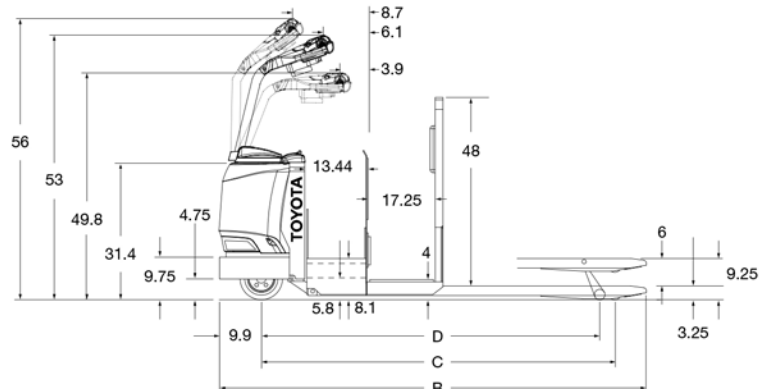

## AISLE REQUIREMENTS – RIGHT ANGLE STACKING (inches)

Pallet Width	Fork Length							
	36	42	48	60	84 <sup>(1)</sup>	93 <sup>(1)</sup>	96 <sup>(1)</sup>	103 <sup>(1)(2)</sup>
36	79.8	85.8	98.8	110.8	142.3	152.2	155.4	155.4
40	79.8	85.8	98.8	110.8	142.0	151.9	155.1	155.1
42	79.8	85.8	98.8	110.8	141.8	151.8	155.0	155.0
48	79.8	85.8	98.8	110.8	141.3	151.4	154.7	154.7

Minimum Aisle Width for Right Angle Stacking.

Includes 4" clearance each side of load.

Add a minimum of 12" for easy maneuvering.

- (1) Forks are designed to handle two 48" pallets.
- (2) These forks are 7" longer to allow for load overhang and proper wheel drop.
- (3) 31.25" x 13.44" when equipped with optional battery compartment rollers.

Pallet 1



For 36-60 inch long forks

Pallet 1 Pallet 2



For 84-103 inch long forks

# 8HBC40 Specifications

## EXTERIOR DIMENSIONS (inches)

A Fork Length	84 <sup>(1)</sup>	93 <sup>(1)</sup>	96 <sup>(1)</sup>	103 <sup>(1)(2)</sup>
B Overall Length	138.7	146.5	148.7	155.7
C Wheelbase – Lowered	105.2	105.2	105.2	112.2
D Wheelbase – Raised	100.5	100.5	100.5	107.5
E Turning Radius	106.6	106.6	106.6	113.5
Gross Weight Without Batteries (lbs)	1940	1980	1990	2015

Units: inches

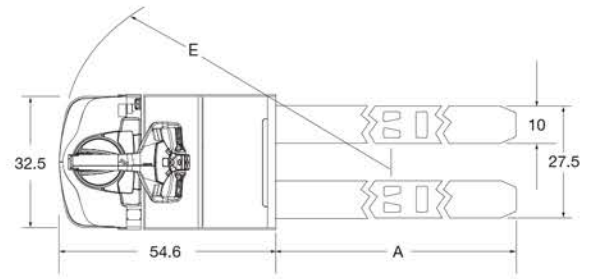

## BATTERY – 24 VOLT

Amps Max. (Ah)	750
Battery Connector/Color	SB-175/Gray
Battery Connector Cable Location	B
Battery Connector Cable Length (inches)	18
Dimensions of Battery Compartment LxW (inches)	31.5 x 13.44 <sup>(3)</sup>
Battery Weight Max. (lbs)	1500
Battery Weight Min. (lbs)	490

## PERFORMANCE

Travel Speed (mph)	Full Load/No Load	6.2/8.8
Gradeability %	Full Load/No Load	8/10

## TIRES

Type	Drive	Standard	Rubber
		Optional	Polyurethane
Size	Load	Polyurethane	
	Casters	Polyurethane	
	Drive – Dia. x Width (inches)	12 x 4.75	
Size	Load – Dia. x Width (inches)	3.25 x 5.91	
	Casters – Dia. x Width (inches)	4 x 2.5	

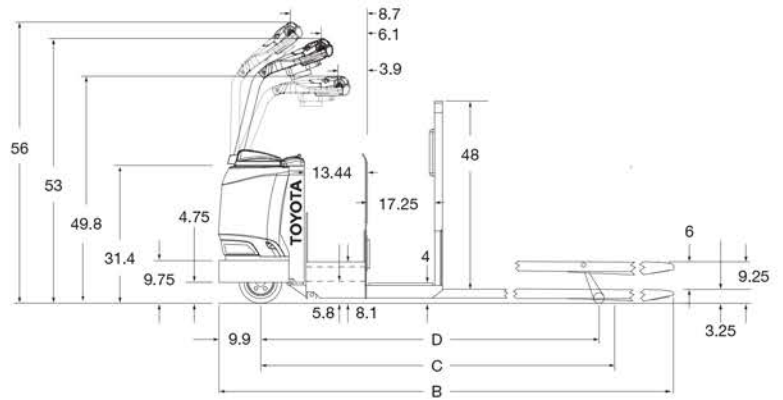

## AISE REQUIREMENTS – RIGHT ANGLE STACKING (inches)

Pallet Width	Fork Length			
	84 <sup>(1)</sup>	93 <sup>(1)</sup>	96 <sup>(1)</sup>	103 <sup>(1)(2)</sup>
36	142.3	152.2	155.4	155.4
40	142.0	151.9	155.1	155.1
42	141.8	151.8	155.0	155.0
48	141.3	151.4	154.7	154.7

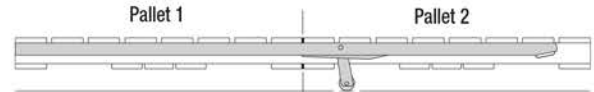

For 84–103 inch long forks

Minimum Aisle Width for Right Angle Stacking.

Includes 4" clearance each side of load.

Add a minimum of 12" for easy maneuvering.

- (1) Forks are designed to handle two 48" pallets.
- (2) These forks are 7" longer to allow for load overhang and proper wheel drop.
- (3) 31.25" x 13.44" when equipped with optional battery compartment rollers.



Some product features described herein are optional. Please consult your dealer for specifications. Details of specifications and equipment are based on information available at time of printing and may change without notice.

00722-8S111-607 8/09  
Litho in U.S.A. (2M)

©2009 Toyota Material Handling, U.S.A., Inc.  
www.toyotaforklift.com

