

7BPUE15



7-SERIES ELECTRIC ORDER PICKER 3,000 LBS SPECIFICATIONS



3,000 lb • Standard Features

PERFORMANCE

- 24-Volt Electrical System
- Independent Lift, Drive and Steer Motors
- Separately Excited (SepEX™) Shunt Wound Drive Motor
- SepEx™ Transistor Control System
- Series Wound Lift Motor
- Multi-Step Thermal Limiting Drive System
- Intuitively Mapped Multifunctional Control Handle
- Two-Speed Lift and Lower
- Hydraulic Lowering Deceleration
- UL-Approved Model Type E

OPERABILITY & MANEUVERABILITY

- Wide-View 2-Stage Mast (V)
- Wide-View 3-Stage Mast (FSV)
- Regenerative Braking
- 40" Base Leg Overall Width
- 39" Wide Operator Platform
- Automatic Return to Center Drive Wheel Upon Start-Up (Auto-Steer Centering)
- Drive Wheel Direction Indicator
- Drive Motor Stall Protection
- Electronic Disc Brake
- Pallet Centering Guide with Automatic Clamp
- Pallet Clamp Release Foot Pedal
- Polyurethane Drive Tire
- Polyurethane Single Load Wheels
- Overhead Guard
- Electronic Power Steering
- Anti-Static Ground Strap
- Forks: 42" x 1.5" x 4"
- Amber Strobe Light
- Tether with Safety Belt
- Electronic Horn

ERGONOMICS

- Bubble-Cushioned Floor Mat
- Low Height – 7.75"
- Fixed Side Gates
- Spring Suspension System
- Anti-Rattle Mast Staging
- Cushioned Mast Stops
- Clipboard and Work Material Storage Compartments
- Flush-Mounted Brake Pedal
- Amenities Tray
- Wire Mesh Mast Guard

SERVICEABILITY

- Power-up and Run Diagnostics
- Battery Discharge Indicator with Lift Interrupt
- Hour Meter (Brake Pedal Activated)
- No Tools Service Access Covers
- Battery Compartment Rollers (Corrosion Resistant)
- Battery Retaining Gates (Adjustable)
- Emergency Power Disconnect Switch
- Emergency Manual Lowering Control Valve
- Enclosed Battery Compartment: 14.5" x 36.75" x 32.25"
- SB350 Battery Connector (Red)

OPTIONAL EQUIPMENT

- UL-Approved Model Type EE
- 13.25" x 31.5" x 32.25" Battery Compartment
- Power Hook-Up for On-Board Terminal
- Cold Storage Conditioning
- Wire Guidance
- Rail Guidance
- Forward and Reverse Travel Alarm
- Lift/Lower Audible Alarm
- Electro-Mechanical Horn
- Twin Light and Fan Package with Independent Controls
- Overhead Guard Mounted Work Lights
- Various Platform Extensions
- Mast Lift-Limit Switch with Bypass
- Mast Lower-Limit Switch with Bypass
- Mast Mechanical Lift Stop
- Flip-Up Side Gates
- Side Gate Power Disconnection Switch
- Speed Reduction at 24"
- Pro-Pack (Productivity Package)
- Various Fork Lengths
- Retractable Tether
- Full Body Harness (36" to 52")
- Guard and Mast Safety Glass Windscreen
- Battery Covers
- Fire Extinguisher
- Red Strobe Light

3,000 lb • Dimensions

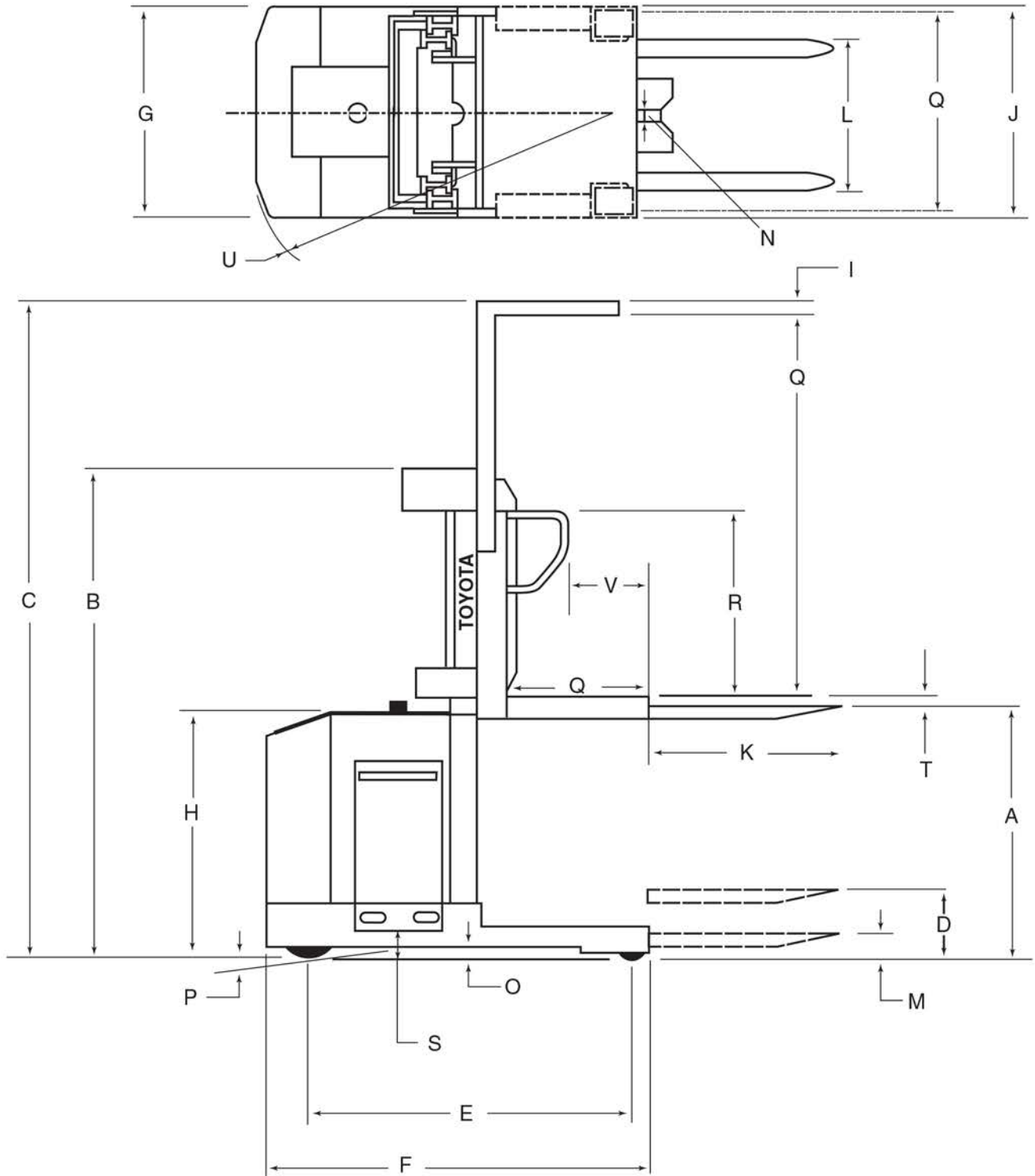

3,000 lb • Specifications

EXTERIOR DIMENSIONS

Model		7BPUE15	
A	Maximum Fork Height		in.
B	Mast Lowered Height		in.
C	Mast Extended Height		in.
D	Free Lift		in.
E	Wheelbase		in.
F	Length to Fork Face (Truck Length)		in.
G	Powerunit Width		in.
H	Powerunit Height		in.
	Overhead Guard Height (Top of OHG to ground)		in.
I	Overhead Guard Thickness		in.
J	Baselegs Overall Width (OAW)		in.
K	Fork Size	TxWxL	in.
L	Fork Adjustment (outside)	Min. / Max	in.
M	Fork Lowered Height		in.
N	Automatic Pallet Clamp Opening		in.
O	Underclearance (center of wheelbase)		in.
P	Grade Clearance ^[1]		%
Q	Operator Compartment Dimensions	LxWxH	in.
R	Fixed Side Gate Height		in.
S	Battery Roller Height		in.
	Platform Height		in.
T	Platform to Top of Forks		in.
U	Turning Radius		in.
V	Picking Window		in.

[1] The Order Picker is designed for level floor operations only. It is capable of being driven in a fully lowered, unloaded condition on a maximum 100 ft. horizontal ramp with a maximum incline of 6%.

3,000 lb • Mast Specifications

7BPUE15 (24V, 14.5" BATTERY COMPARTMENT - STANDARD)

Mast Type	Maximum Fork Height (top of forks) in	Overall Height		Free Lift in	Load Capacity @ 24-Inch Load Capacity [2] lb
		Lowered in	Extended in		
V	123	88.5	208	-	3000
	137	95	222	-	3000
	161	107	246	-	3000
	201	127	286	-	3000
	241	147	326	-	3000
FSV	189	88.5	274	3	3000
	210	95	295	10	3000
	240	107	325	22	3000

Note: Base Legs Overall Width is 40-inches.

[2] With minimum 1600lb battery.

7BPUE15 (24V, 13.25" BATTERY COMPARTMENT - OPTION CODE 4556)

Mast Type	Maximum Fork Height (top of forks) in	Overall Height		Free Lift in	Load Capacity @ 24-Inch Load Capacity [3] lb
		Lowered in	Extended in		
V	123	88.5	208	-	3000
	137	95	222	-	3000
	161	107	246	-	3000
	201	127	286	-	2500
	241	147	326	-	2000
FSV	189	88.5	274	3	3000
	210	95	295	10	3000
	240	107	325	22	2500

Note: Base Legs Overall Width is 40-inches.

[3] With minimum 920lb battery

3,000 lb • Specifications

Model		7BPUE15
Type		Order Picker
Load Capacity (with 24 inch load center)	lb.	3000
Body/Frame Construction		Welded Steel Body and Frame
Steering Type		Electronic Power Steering
Brake Type		Electronic Disc Brake

PERFORMANCE DATA^[1]

Model				7BPUE15	
Steering Angle				Steering Angle ≤ 10°	Steering Angle > 10°
Maximum Travel Speed (Standard)	0" - 24" MFH	Unloaded	mph	5.7	5.7
	24" - 60" MFH	Unloaded	mph	3.0	1.0
	60" - 150" MFH	Unloaded	mph	3.0	1.0
	150" - 180" MFH	Unloaded	mph	3.0	1.0
	180" - 241" MFH	Unloaded	mph	3.0	1.0
Lifting Speed	Full Load/No Load		fpm	30/40	
Lowering Speed	Full Load/No Load		fpm	70/65	

Increased Travel and Lifting Speeds with Pro-Pack (Option Code - 4605)				7BPUE15	
Steering Angle				Steering Angle ≤ 10°	Steering Angle > 10°
Maximum Travel Speed (Optional)	0" - 24" MFH	Unloaded	mph	5.7	5.7
	24" - 60" MFH	Unloaded	mph	5.7	2.5
	60" - 120" MFH	Unloaded	mph	4.3	1.0
	120" - 150" MFH	Unloaded	mph	2.5	1.0
	150" - 180" MFH	Unloaded	mph	2.5	1.0
180" - 241" MFH	Unloaded	mph	1.0	1.0	
Lifting Speed	Full Load/No Load		f.p.m.	40/60	
Lowering Speed	Full Load/No Load		f.p.m.	70/65	

[1] Based on a truck equipped with a 95"/204" FSV mast.

BATTERY

Model				7BPUE15	
Compartment Dimensions	Standard	LxWxH	in.	36.75 x 14.5 x 32.25	
	Optional			31.5 x 13.25 x 32.25 ^[2]	
Voltage Capacity (6-hour ratings)		24V	V/Ah	24/1085	
Minimum Weight ^[3]	Standard		lbs.	1600	
	Optional			920	
Maximum Weight			lbs.	2000	

[2] Optional reduced battery compartment size achieved with battery spacers.

[3] The 'Minimum Battery Weight' indicated is the lightest battery required to satisfy stability requirements of the lift truck.

CONTROL TYPE

Model		7BPUE15
Drive		Transistor
Load Handling		Contacttor
Power Steering		Transistor

TIRES

Model				7BPUE15	
Type			Drive	Polyurethane	
			Load	Polyurethane	
Size	Drive		in.	12 x 5	
	Load		in.	6 x 3.6	



Some product features described herein are optional. Please consult your dealer for specifications. Details of specifications and equipment are based on information available at time of printing and may change without notice.

00722-35175-205 5/14
Litho in U.S.A. (1M)

© 2014 Toyota Material Handling, U.S.A., Inc.
www.toyotaforklift.com



Toyota is the number one selling lift truck in the United States.